



TRIG WARRANTY

Trig Avionics warranty runs for a two-year period, starting from the date of installation.

This warranty covers repair and/or replacement at our option, of any parts found to be defective, provided such defects in our opinion are due to faulty material or workmanship and are not caused by tampering, abuse, or normal wear.

Our warranty service is provided FCA our location or our other associated Trig Service Centres.

Trig Avionics will not accept or pay for any charges for warranty work performed outside our factory without prior written consent.

This warranty applies only to products in normal use. It does not apply to units or circuit boards defective due to improper installation, physical damage, tampering, lightning or other electrical discharge, units with altered serial numbers, or units repaired by unauthorized persons or in violation of Trig Avionics service procedures.

Trig Avionics assumes no responsibility for any consequential losses of any nature with respect to any products or services sold, rendered, or delivered.

Out of Warranty Repairs

Trig provides product support beyond the warranty period of two years. After this period, any avionics requiring repairs should be returned to one of our Approved Trig Dealers. If a repair is necessary this will be charged at a standard rate, irrespective of the nature of the fault. Trig guarantees to repair or replace a product even if the cost of the repair exceeds our standard charge. If you wish to access our out of warranty support, then please contact your Approved Trig Dealer or Trig Support for further information.

TA10
INSTALLATION

GUIDE
02459-00 AA

Trig Avionics
Hardwareweg 3
3821 BL Amersfoort
Netherlands

Thank you for purchasing a Trig TA10 VHF Com antenna.

This pack contains installation information and support and warranty information.

All our avionics are thoroughly tested prior to despatch and are designed to provide years of trouble free service. To access technical support for your Trig Avionics product you should first contact your Approved Trig Dealer.

If you have any further technical questions, then please access your closest Trig Service Centre through the support section of our website.

www.trig-avionics.com/support/

Thanks,

The Trig Team
enquiries@trig-avionics.com

INSTALLATION GUIDE

1. The antenna should be located at least 0.6 m (2 ft) away from other antennas and reflective surfaces on the airframe (e.g., vertical stabilizer, landing gear, etc.). A good electrical connection must exist between the antenna mounting hardware and the metal frame or skin of the aircraft.
2. **Composite or Wood Aircraft** - Create a “ground plane” on the inside of the aircraft skin by preparing two 1.2 m (48”) long, light gauge copper wires, perpendicular to each other and intersecting at their mid-point (forming an X). Strip away insulation at this intersection if using insulated wire. Locate this on the inside of the aircraft skin where the antenna will be mounted externally. Run the wires forward, aft and side to side along the inside wall and secure in place. Attach the (X) intersecting point to one of the antenna’s mounting bolts, making a good electrical connection. This is similar to a communications antenna you would see at a ground installation; a vertical radiator with four ground plane “radials” equally spaced around the base.
3. Using the template provided, drill four mounting holes and one hole for the connector. The template is not symmetrical; note the ‘front’ and ‘rear’ on the template.
4. Mount the antenna by placing the rubber pad provided between the antenna base and aircraft skin, and the back-up plate provided inside the aircraft. Insert hardware provided as shown below and tighten all mounting screws securely to provide a good electrical contact. The antenna must be properly grounded by means of the countersunk washers biting through the painted surface under the mounting screw heads.
5. Using RG-400 or similar 50 ohm coax cable (not supplied), attach a BNC connector to one end. The other end of the cable must have a connector attached to match the connector on the radio.
6. Place the cable with the connectors attached between the antenna and the radio. Test the antenna by connecting an in-line wattmeter between the transmitter and the antenna. VSWR should be 2.0 to 1.0 or better for satisfactory operation.

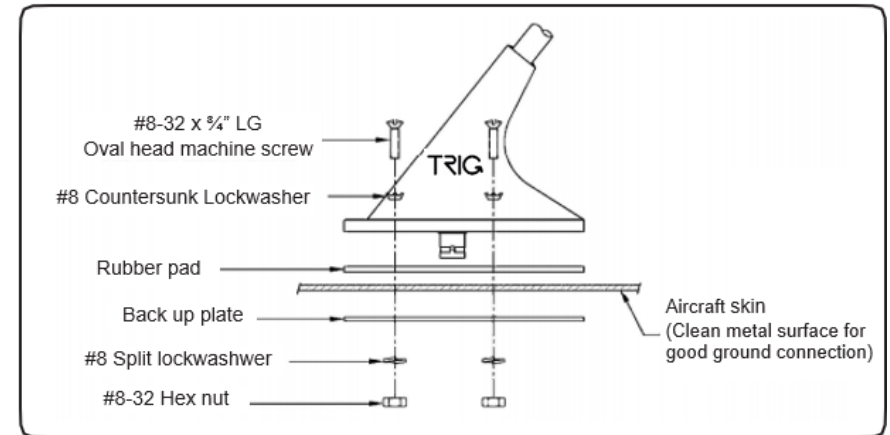

SPECIFICATIONS

TA10 – VHF Com Antenna - straight

The TA10 is designed for standard and high-performance aircraft applications. It exhibits excellent electrical characteristics and incorporates an efficient aerodynamic 4-bolt mounting base. The antenna is suitable for most single and twin general aviation aircraft.

The TA-10 is designed to operate at speeds of 350 mph and altitudes up to 50,000 feet. It has a drag force of 2.70 lb @ 250 mph. The TA-10 is certified to FAA TSO-C37d and TSO-C38d.

Frequency:	118 MHz – 137 MHz
Impedance:	50 ohm nominal
VSWR:	2:1 maximum
Polarization:	Vertical
Pattern:	Omni-Directional
Connector:	BNC female
RF Power capacity	30 W
Max. height/weight	523 mm (20.6”) / 226 g (8 oz)